

Specification	Multipurpose clamp for 2 x 16mm conductor. With nut and spring washer. Fastening in stainless steel. Hot dip galv. steel. Weight: 182,00 g Reference Standard: DIN 62561-1
Article No.	42 06 17

Customs tariff number.: 85389099

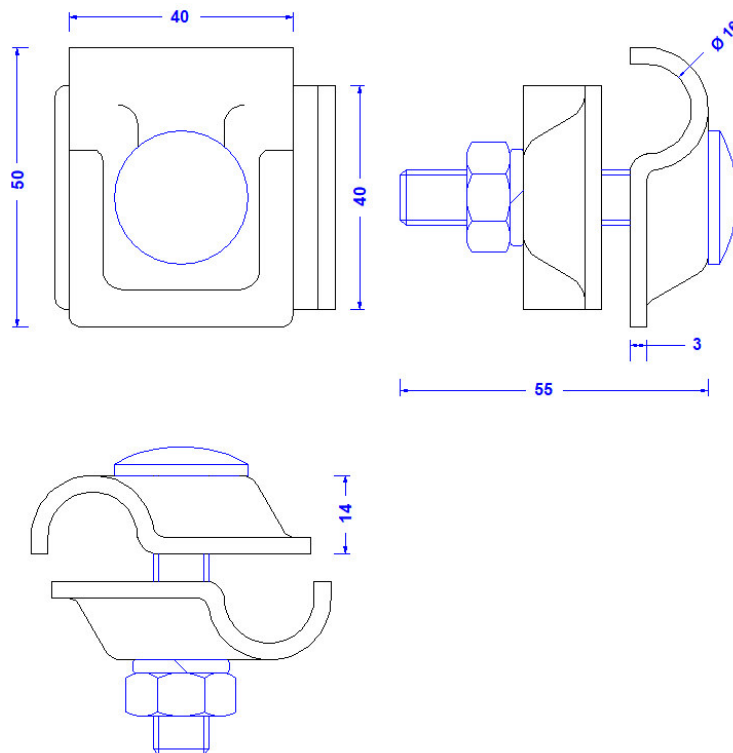

Used for example as a T-, parallel or cross-clamp.

Description	RoHS2 (Guideline 2011/65/EU) and REACH (Regulation (EG) No.1907/2006): The substance-requirements and all other requirements of this regulations are observed by this product.
Material of the clamp	Steel ST37. hot-dip galvanised .
Conductor leading	2 x 16 mm conductor, parallel or crossed. Hot-dip galvanised steel
Screw connection (all stainless steel)	Screw: DIN603M10X55, nut: DIN934M10 spring washer: 10mm.